

### Maintenance of the Lights 水下灯保养与维护

- Do not leave the lights "on" above water for longer than 1 minute. (水下灯不可以没有水的情况下点亮超过1分钟)
- Do not leave the lights directly under sunlight. Fill the pool with fresh water as soon as possible after the lights are installed. (水灯装好到泳池内, 应尽快将泳池内注满水, 水下灯不可以长时间在太阳光下曝晒)
- Before switching on the lights, check whether the lights are fully submerged underwater and the circuit boxes are running properly. (装好水下灯点亮前, 要检查水灯是否完全浸在水中, 电箱和电路是否正常)
- This unit does not need any kind of maintenance. If it is not working properly, please contact EMAUX authorized dealer where you purchase the unit from. (此产品不需要任何维修, 如果不正常工作, 请联系你购买此产品Emaux授权的经销商)
- Warranty will be voided if the Emaux Underwater Light was dismantled by unauthorized personnel. (如果Emaux水下灯被未经授权人拆卸则保修视为无效)

### REPLACEMENT PARTS

项目	部件编号	中文描述	英文描述	数量
Item No.	Part No.	Description Chinese	Description English	Qty
1	01050102	面盖	Face plate	1
2	01040212	透明罩	Lights Lens	1
3	01110027	压紧螺钉	Compression screw	1
4	03011132	M4*8圆头自攻螺丝	M4*8 Head self-tapping screws	3
5	04011073	灯泡	Bulb 12V/75W	1
5-1	04011020	LED灯盘(198灯珠8W彩光)	Bulb plate(RGB colour) 12V/8W 198LEDs	1
	04011014	LED灯盘(198灯珠8W白光)	Bulb plate(white colour only) 12V/8W 198LEDs	1
	04011114	LED灯盘(102灯珠6W彩光)	Bulb plate(RGB colour) 12V/6W 102LEDs	1
	04011103	LED灯盘(102灯珠6W白光)	Bulb plate(white colour only) 12V/6W 102LEDs	1
6	03017118	反光片	Mirror	1
6-1	03011094	M3*6圆头自攻螺丝	M3*6 Head self-tapping screws	2
7	02021084	丁晴胶O形胶圈	O-ring	1
8	01231008	底壳	Body set	1
9	04013004	电缆线	Cable 2.5M	1
10	89044501	纤维池配件	Vinyl pool Fitting	1
11	89040203	水泥池配件	Concrete pool Fitting	1
12	03011321	平头自攻螺丝	M5X20 flat head self-tapping screw	1

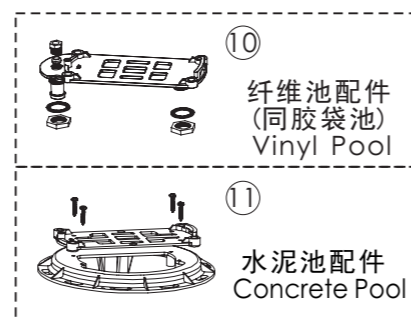
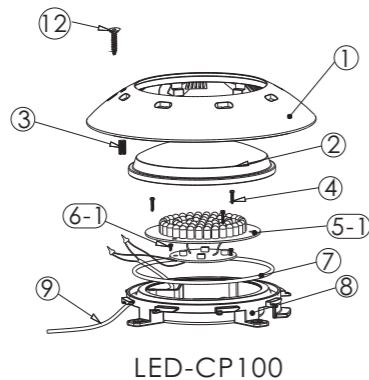
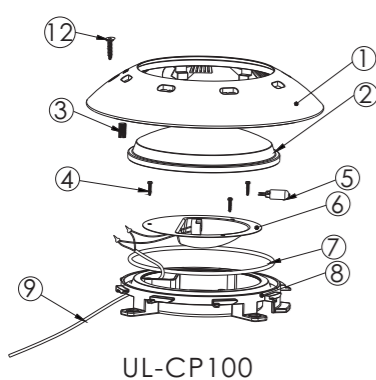

UL-CP100

LED-CP100

## UL-CP100 LED-CP100

### ROTARY TYPE UNDERWATER LIGHT OPERATING MANUAL

#### UL-CP100 LED-CP100旋转式水下灯说明书

#### Keep this manual for future reference

请保留此份说明书以备用



#### SAFETY WARNINGS 安全警告

- Only qualified electrician is allowed to carry out the installation of this product. (必须由持牌或经过核证的电工或专业的泳池安装人员才能进行安装)
- Avoid direct contact with electrical power. (避免与电源直接接触)
- Respect all regulations in effect for preventing accidents. (遵循所有规则防止引起事故)
- All units are required to be disconnected from the main electricity before any operation of maintenance. (在维修和安装水灯前, 要断开总电源)
- Never handle with wet hands and feet. (不能够用湿的手脚操作)
- This unit is design for use only when fully submerged in fresh water, connecting with a safety transformer. (此产品的设计完全用于完全浸泡于清洁的水中, 连接认可的安全隔离变压器)
- Never operate this Underwater Light for more than 1 minute unless it is totally submerged in water. (不要超过1分钟操作, 除非完全浸泡于水中)
- Be sure power is off before installing or removing light bulb. Allow light bulb to cool before replacing. (在安拆灯泡之前确保电源已关掉, 灯泡降温后才允许更换)
- This product should be installed according to your local electrical installation ordinances and regulations. (应遵守当地用电安装条例和规则安装此产品)
- Maximum Depth for Light installation at 1 meter (水灯安装离水面最深为1m).
- Maximum Water Temperature Range for light operation 0 - 30°C (水温度范围0- 30°C)

#### SPECIFICATION 规格

A. Electrical Specification: 1) Voltage: AC12V 2) Frequency: 50Hz 3) Power: 75W (UL-CP100), 6W/8W (LED-CP100) (水下灯参数: 电压: AC 12V 频率: 50Hz 功率: 75W (UL-CP100), 6W/8W (LED-CP100))

#### INSTALLATION NOTES 水灯安装注意事项

- 1) Each cable is 2.5m long. You should follow the procedures closely when installing the light. (水下灯的电缆线有2.5米长, 在安装水灯时应该严格按照水灯操作说明进行)
- 2) It is recommended to install a light every 20m<sup>2</sup>, the approximate exposure area of each unit. (水灯的照射面积约20平方米, 即在20平方米的水面要装一个水灯)
- 3) The lights should be installed in the direction that they will not shine directly into the house. (为了防灯光刺眼, 水灯必须安装在灯光不会直射房子的方向)
- 4) For training or competition pools, the lights must be installed on the sides in order to prevent swimmers from seeing any glare. (如果是比赛或训练用游泳池, 水灯必须用在游泳池两侧为了防止游泳者看到产生眩光)
- 5) Nothing should be placed on the poolside directly above the lights for ease of future maintenance. (为了方便灯具维护, 灯具上面的游泳边上必须空出一块地方)
- 6) If the wires are connected inside the lights, you must seal the connections with leak-proof tapes or products with the same function. (如果水下灯的接线处在水灯中时, 你必须用防水胶带或用其它胶将接线处密封好)

- 7) The cables connecting the lights and the transformers must be at least 6mm<sup>2</sup> and the distance between them must not exceed 30m (Figure 2); otherwise the lights will not function properly. (水灯到变压器的之间的电缆线不可少于6mm<sup>2</sup>, 安装距离不可以超过30米。(如图2); 因电缆线规格小或安装距离太长, 线路会有损耗, 电压就达不到12V, 水下灯就不可以完全点亮)

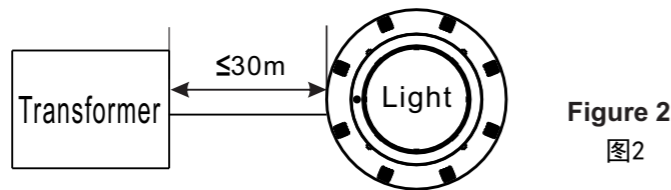

Figure 2  
图2

### INSTALLATION OF THE UNDERWATER LIGHT 水下灯的安装

#### A) Preparing to Install 安装准备

- 1) Before installation, a circuit system diagram must be designed by a certified engineer. (在安装水下灯前, 要有专业设计人员来完成整个游泳池的水下灯电路系统图)
- 2) The circuit system must comply with local laws and regulations and must be carried out by qualified electricians. (保证电路系统符合当地法规的要求; 必须要有一个合格的水电工程师才能安装水下灯)
- 3) Make sure the voltage is 12V and the terminal box is at least 120cm from the poolside (Figure 3). (确保连接水灯的电压为12V, 接线盒位置安装距离池边最少120厘米。(如图3))
- 4) Upon installation, top of the light must be at least 45cm from water surface (Figure 3). (入墙牌要安装在指定位置上, 以便挂上灯后, 灯的顶部最少距离水面45厘米。(如图3))

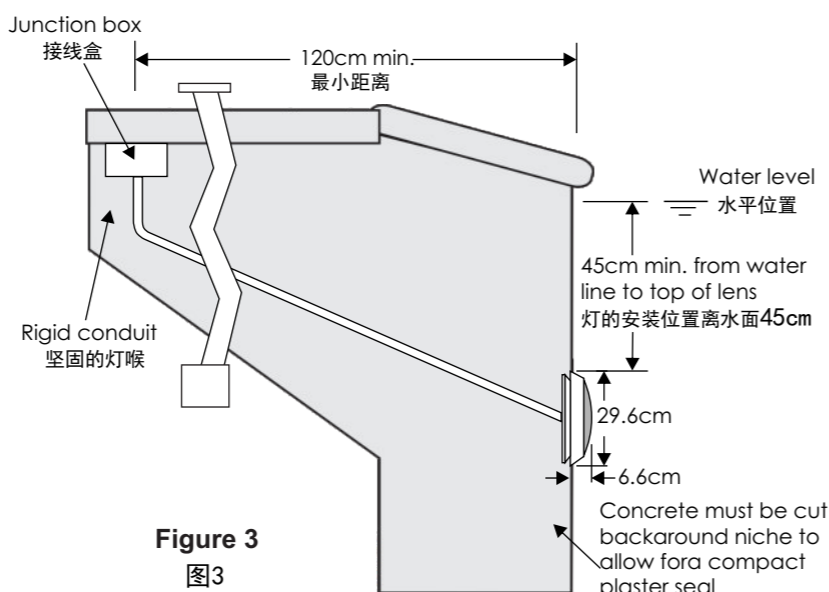

Figure 3  
图3

### WARNING 警告

- ⚠ Never operate this Underwater Light for more than 10 seconds unless it is totally submerged in water. Without total submersion, the light assembly will get extremely hot, which may result in serious injury to pool users, installers, or bystanders, or in damage to property.
  - ⚠ Be sure power is off before installing or removing lamp. Allow lamp to cool before relamping. This light fixture uses a Halogen Quartz lamp. Do Not touch lamp with bare hand, this may severely reduce its life. Use the plastic furnished with the replacement lamp to eliminate finger prints from getting on lamp.
- 如果水下灯不被水完全覆盖住, 就不要开启水下灯多过10秒。因为这样会变得非常热, 从而导致泳池使用者, 安装人员或旁观者严重受伤; 对环境亦会造成破坏。把电源关掉才可安装或维修; 要灯泡降温后再重开。这灯泡是卤素石英灯泡。不要触摸灯泡外露的针, 这会严重减低寿命。

#### B) Pool Installation 泳池安装

- 1) Embed the Wall Mount into the concrete wall, making sure that it is parallel to the side of the pool (Figure 4). (将入墙牌镶入泳池壁内, 入墙牌的表面要与泳池完成面相平。(如图4))
- 2) Place the Mounting Plate on the concrete wall and tighten it with 4 screws. The conduit must be next to the Mounting Plate (Figure 5). (收紧4颗螺丝, 将挂墙牌固定到入墙牌的泳池面上; 穿线孔的位置必须在入墙牌和挂墙牌两边的空隙内。(如图5))
- 3) Note that the light must only be installed on a flat or concave surface. (灯要安装在平滑表面或在内弯表面, 墙壁不规则或不平的表面不可以安装)
- 4) Wrap extra cables behind the light to make sure it could be taken to the pool surface for future maintenance (Figure 6). (缠绕一部分的电缆电在灯的后面; 要保证电缆电足够长, 可以将灯拿出水面维修。(如图6))
- 5) Hang the light onto the Mounting Plate and tighten the screws (Figure 7). (将灯挂到挂墙牌上, 收紧上面的螺丝。(如图7))

- 6) The wire connections inside the terminal box must be sealed by leak-proof tapes to prevent water from leaking into the terminal box through the cables. (泳池边接线盒内的接线处一定要用防水胶带密封好, 防止水延电缆线内部渗入水灯内)

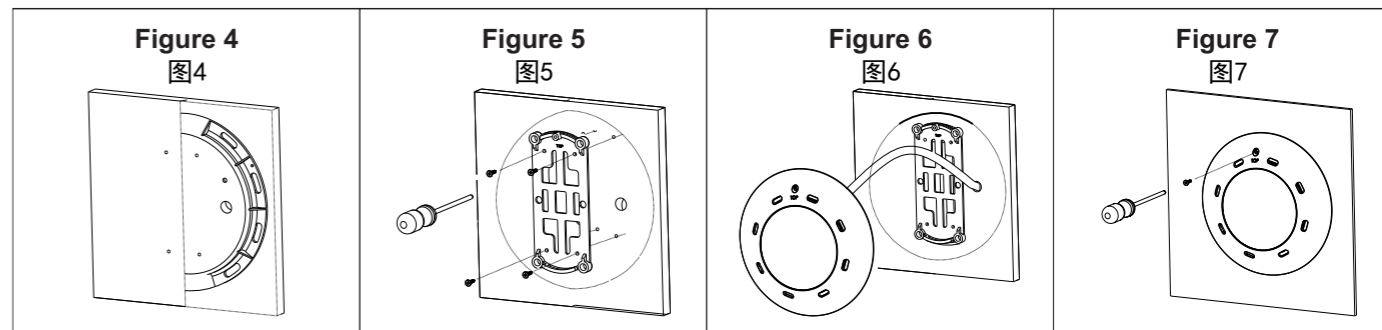

#### C) Fiberglass Pools / Vinyl Pools Installation 纤维池及胶袋池安装

- 1) Refer to section "Preparing to Install". (参照安装准备部份. 定好要装水灯的位置)
- 2) Make 2 holes on the pool wall (Figure 8). (按图8要求开2个孔)
- 3) Place the o-rings between the Mounting Plate and the pool wall and tighten it with the Nut on the other side of the pool wall (Figure 9). (在安装板与池壁之间放置胶圈, 然后在池壁的另一边用螺母固定。(如图9))
- 4) Put the cable sequentially through the sealing Nut, the sealing O-ring and the cable hole on the mounting plate; then tighten the Nut (Figure 10). (将牙头和电缆胶圈依次穿到电缆线上, 再穿过挂墙牌的线孔, 然后将牙头收紧。(如图10))
- 5) Wrap extra cables behind the light to make sure it could be taken to the pool surface for future maintenance. Then, hang the light onto the Mounting Plate and tighten the screws (Figure 11). (缠绕一部分的电缆电在灯的后面, 将灯挂到挂墙牌上, 收紧上面的螺丝。(如图11))

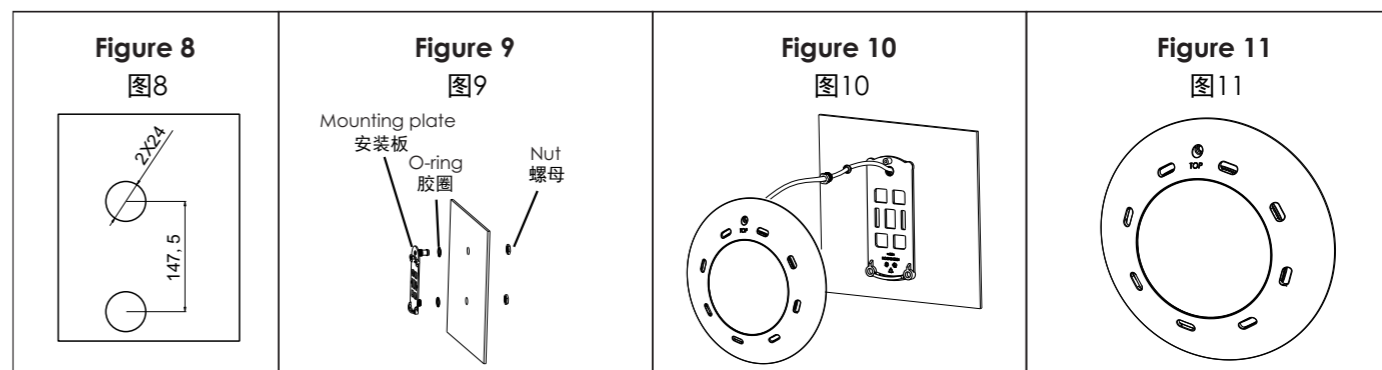

#### D) Assembly for CP100 水下灯的安装与拆卸

- 1) Clean the O-ring installation position and put the O-ring. (Figure 12) (将底壳上的胶圈位清理干净, 再放入胶圈(如图12))
- 2) After install the O-ring. Put the transparency lid and then put the cover. (Figure 13) (装好胶圈后, 依次将透明盖与面盖装好(如图13))
- 3) While install the cover with the base, please to note that the sign of "TOP" from the base should meet with the sign of "TOP" for the cover. (Figure 14) (装面盖时要注意将底壳上的TOP对准面盖上的TOP, 将面盖逆时针向旋转安装水灯(如图14))
- 4) Rotate to the station position and then to use screw driver that to tighten. (Figure 15) (旋转到位后用螺丝刀收紧定位(如图15))
- 5) For Unassembled, please to reverse the sequence. (如需拆卸水下灯请安以上步骤想反操作)

